

Non-contact Line-laser Sensor SurfaceMeasure 1008S

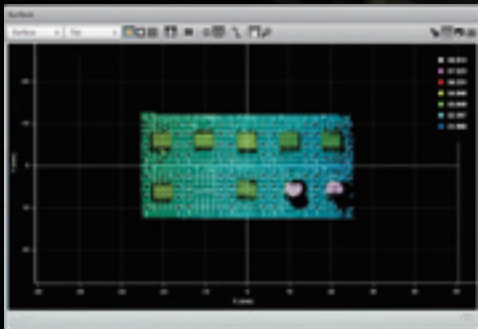

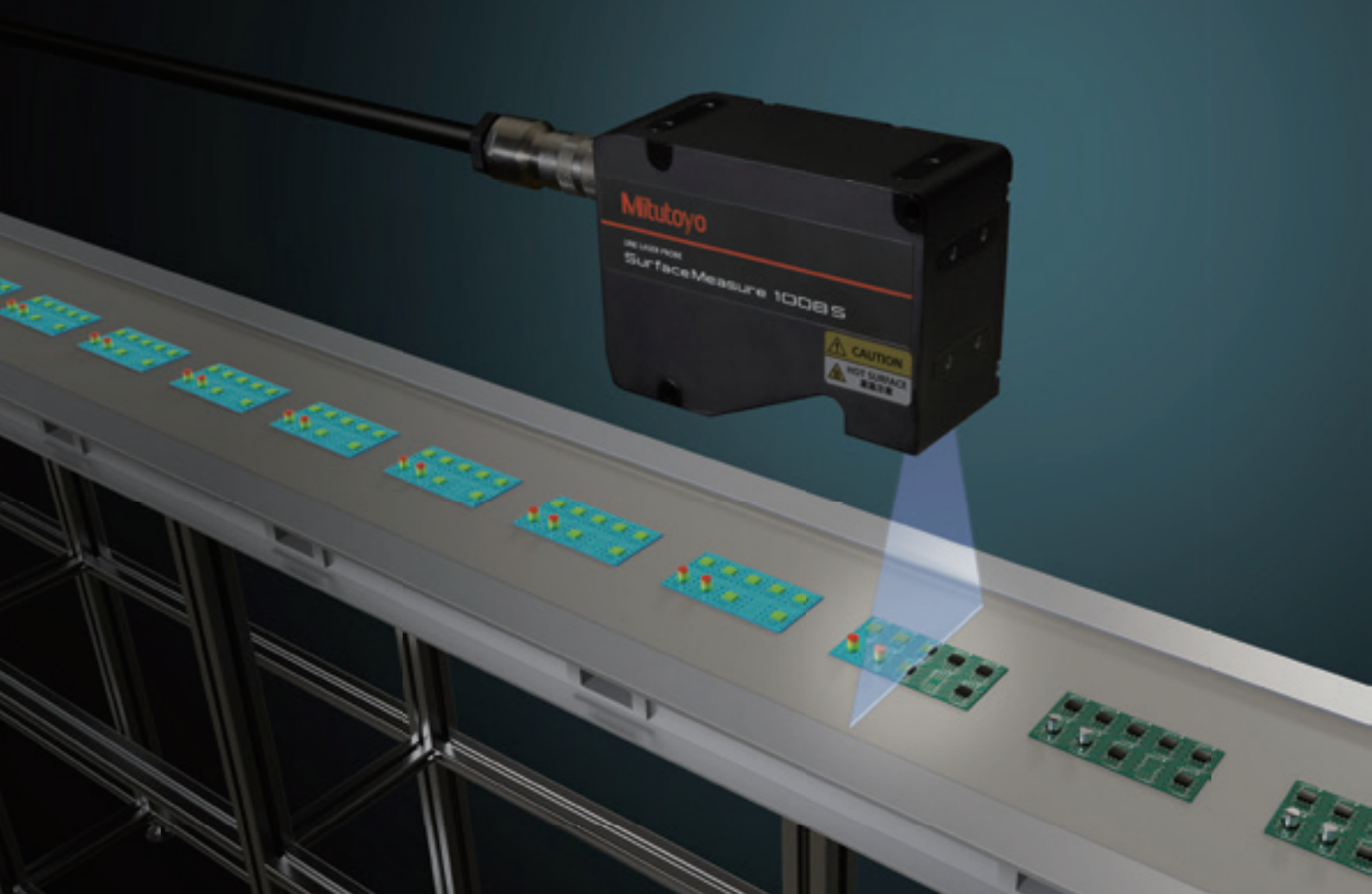

Line-laser sensor providing stable measurements with simple operations



System configuration (example)

This is an example of the system configuration of Surface Measure 1008S. Various other system configurations are also available.

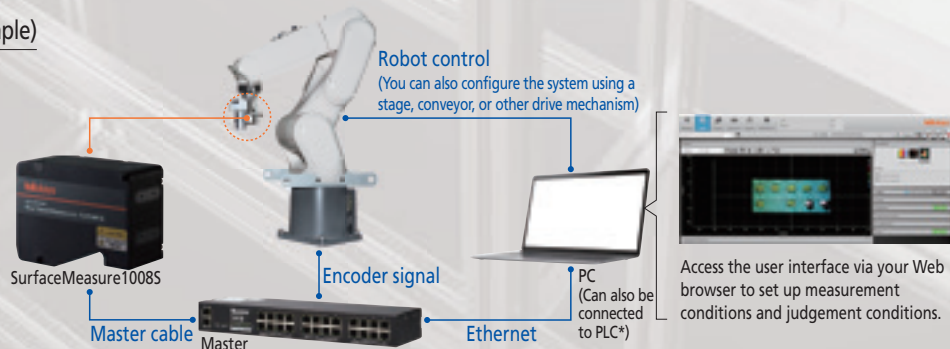

* PLC protocol: Modbus TCP, EtherNet/IP, PROFINET

Product structure

This line-laser sensor combines the optical technology and sensor technology of Mitutoyo.

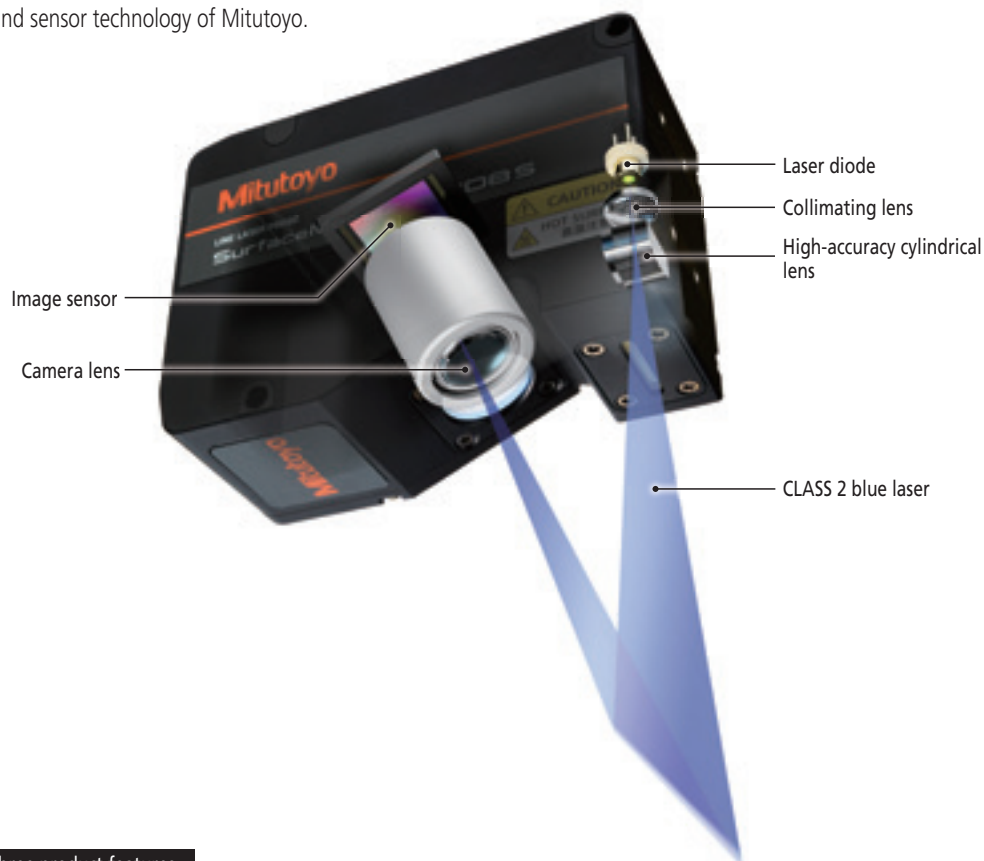

Three product features

— (1) High-accuracy and environment-resistant sensor

The sensor itself is guaranteed for an accuracy of 20 μm (1σ) and a Z repeatability of 0.5 μm . It has also achieved the IP67 protection level, providing stable measurements.

— (2) Supporting automated measurement

The **SurfaceMeasure1008S** can obtain the profiles and three-dimensional shapes of measurement workpieces at high speed (a maximum frame rate of 10 kHz) and make an automatic judgement inside the sensor. It is also equipped with a parts matching function that allows the measurement tool to be applied throughout, regardless of the orientations of the parts being measured. Measurements can be taken without performing alignment.

— (3) Simple operability

The software supports intuitive operation and is built into the sensor (software installation is not required), so you can use it immediately after mounting.

APPLICATION

Automobile industry

Panel gap inspection

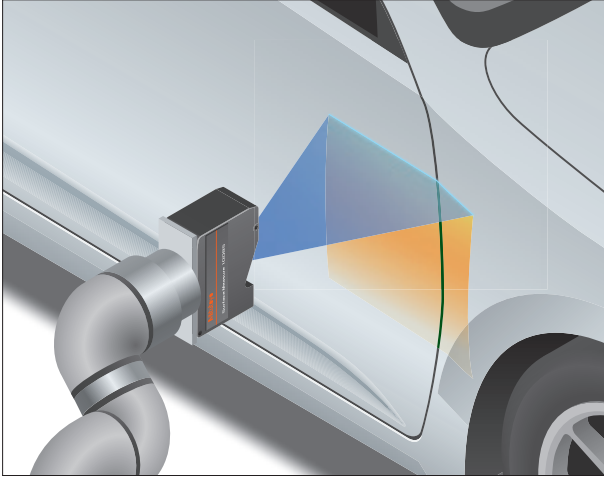

Rubber and tire industries

Tire shape inspection

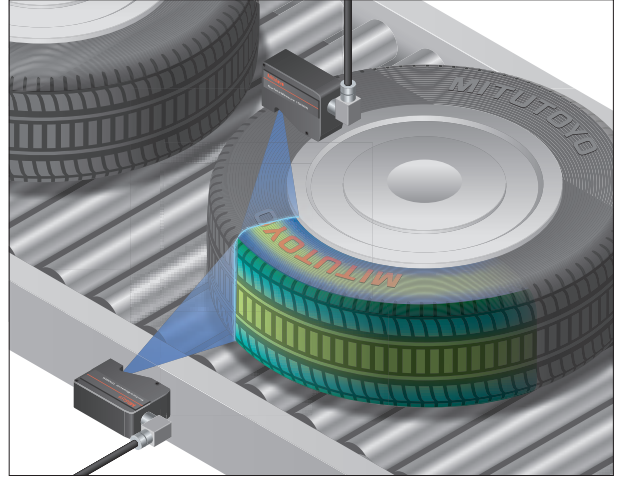

Electric vehicle battery industry

Cell assembly inspection

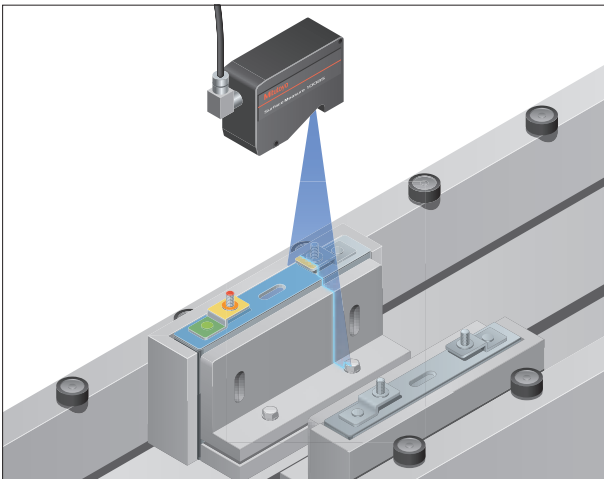

Electrical and electronic industries

Adhesive inspection

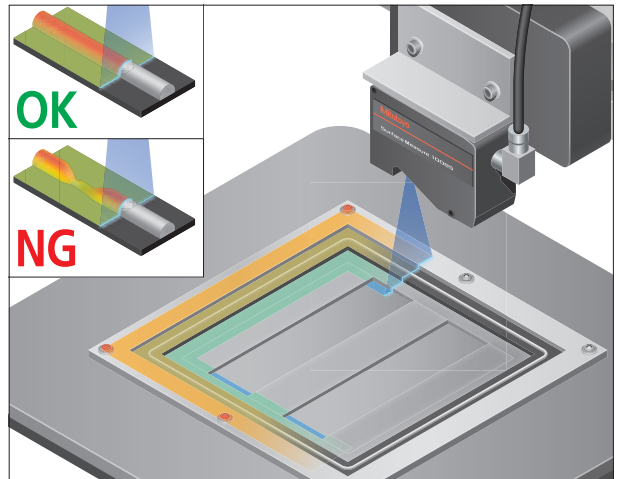

Electrical and electronic industries

Connector pin inspection

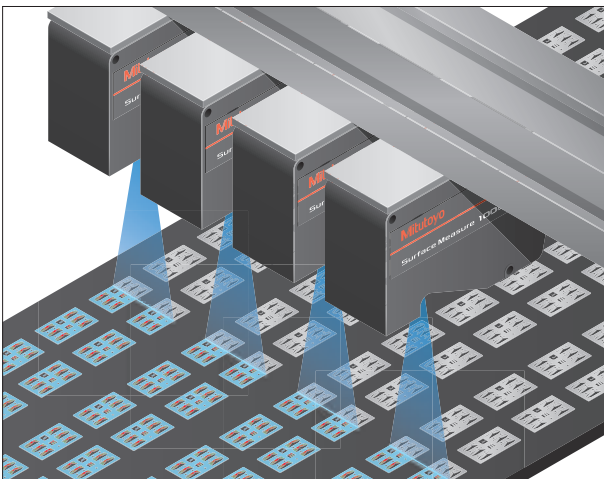

Food industry

Standard inspection of food, etc.

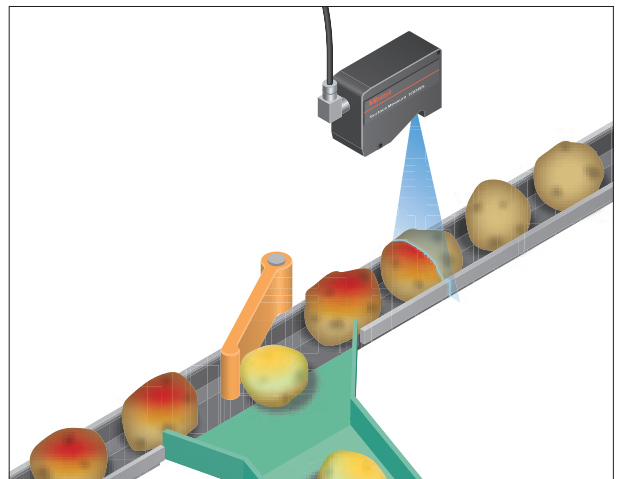

SOFTWARE

Powerful interface with excellent operability and functionality

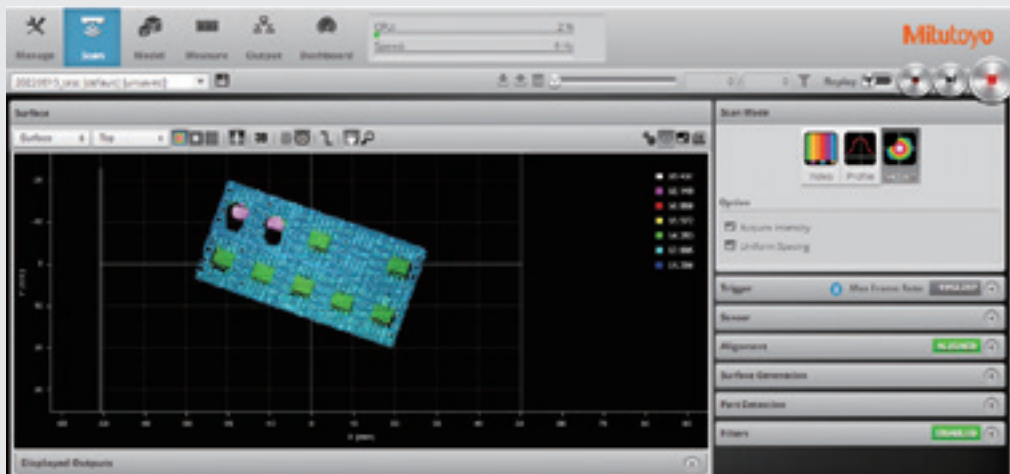

- Excellent operability simply by using a mouse
- Simple and intuitive interface
- Web browser-based, no need to install software
- Various built-in measurement tools
- 2D and 3D data can be obtained



Easy-to-configure measuring system

Measurement tool

- Pattern matching
- Countersink Hole
- OCR (Optical character recognition)
- Gap & Flush
- Groove
- Size

Various measurement tools such as these are available.



Pattern matching

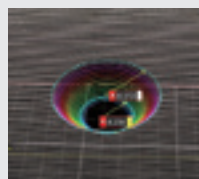

Countersink Hole

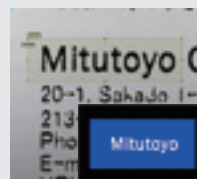

OCR

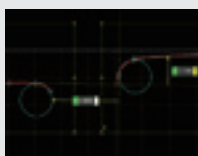

Gap & Flush

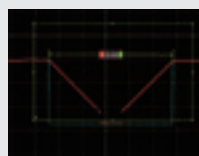

Groove

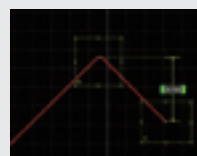

Size

Emulator

Using the emulator makes it possible to consider measurement conditions or make an analysis with obtained data even when offline.

SurfaceMeasure1008S

Specifications

| Code No. | | 553-100 | |
|----------------------------------|--------------|------------------------------|---|
| Maximum measuring width | | 100 mm | |
| Measuring range | | 80 mm | |
| Working distance | | 80 mm | |
| Scanning error (1 σ) *1 | | 20 μ m | |
| Frame rate | | Max. 10 kHz | |
| Laser class | | EN / IEC | CLASS 2 (IEC 60825-1: 2014, EN 60825-1: 2014+A11:2021) |
| | | JIS | CLASS 2 (JIS C 6802: 2014) |
| Line laser | Laser medium | Semiconductor laser | |
| | Wavelength | 405 nm (visible) | |
| | Max. output | 2.2 mW | |
| Mass | | 650 g | |
| Operating temperature | | 0 °C to 40 °C | |
| Operating humidity | | RH 20 to 80%, non-condensing | |
| Storage temperature | | -30 °C to 70 °C | |
| Storage humidity | | RH 20 to 95%, non-condensing | |
| IP code | | IP 67 *2 | |
| Power supply (power consumption) | | 24 to 48 VDC (15 W) | |

*1 Accuracy inspection environment: Temperature 20 °C \pm 1 °C, Humidity 50%RH \pm 10%RH

Measurement workpieces: Specified reference ball for inspection (ϕ 30 mm)

Inspection method: Determined by Mitutoyo-specified inspection method.

The operating environment and the storage environment are different from the guaranteed accuracy environment.

*2 Measuring accuracy may deteriorate if any water droplet or dust particle adheres to the optical path.

External dimensions

Unit: mm

• Measuring range

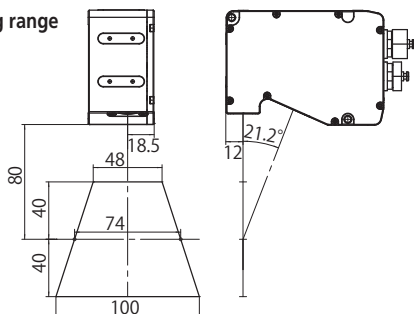

• Mounting size

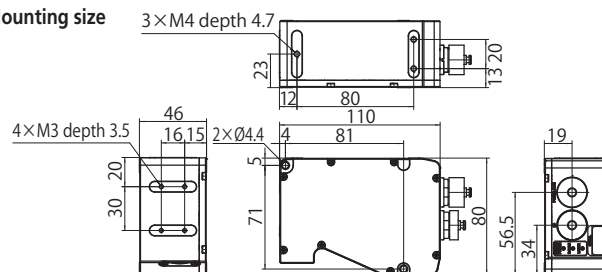

Sensor networking hub Master

In the multi-sensor system, this device is used for distributing power to sensors and synchronizing the sensors.

Input: Power supply 24 to 48 V, Laser Enable input, Encoder input, External input



Master2410

| Code No. | Product Name | Remarks |
|----------|--------------|-----------------------------------|
| 02AQL401 | Master810 | Accepting a maximum of 8 sensors |
| 02AQL402 | Master2410 | Accepting a maximum of 24 sensors |

Master cable

Cable for the connection between sensor and Master.



| | | |
|----------------|--------------------|--|
| Specifications | Sensor side | M16 connector (Straight or 90° upward-pointing can be selected) |
| | Power supply side | RJ45 (Connect to Master) |
| | Communication side | RJ45 (Ethernet connection) |

| Code No. | Product Name | Remarks |
|----------|--------------------------------------|------------------------------|
| 02AQL373 | 2 m Power and Ethernet Master | 2 × RJ45 ends |
| 02AQL374 | 5 m Power and Ethernet Master | 2 × RJ45 ends |
| 02AQL375 | 10 m Power and Ethernet Master | 2 × RJ45 ends |
| 02AQL376 | 15 m Power and Ethernet Master | 2 × RJ45 ends |
| 02AQL377 | 20 m Power and Ethernet Master | 2 × RJ45 ends |
| 02AQL378 | 25 m Power and Ethernet Master | 2 × RJ45 ends |
| 02AQL391 | 2 m Power and Ethernet Master 90deg | 2 × RJ45 ends, 90° connector |
| 02AQL392 | 5 m Power and Ethernet Master 90deg | 2 × RJ45 ends, 90° connector |
| 02AQL393 | 10 m Power and Ethernet Master 90deg | 2 × RJ45 ends, 90° connector |
| 02AQL394 | 15 m Power and Ethernet Master 90deg | 2 × RJ45 ends, 90° connector |
| 02AQL395 | 20 m Power and Ethernet Master 90deg | 2 × RJ45 ends, 90° connector |
| 02AQL396 | 25 m Power and Ethernet Master 90deg | 2 × RJ45 ends, 90° connector |

Power and Ethernet cable

Cable to supply and control power without using the Master for the sensor



| | | |
|----------------|--------------------|--|
| Specifications | Sensor side | M16 connector (Straight or 90° upward-pointing can be selected) |
| | Power supply side | Flying lead |
| | Communication side | RJ45 (Ethernet connection) |

| Code No. | Product Name | Remarks |
|----------|-------------------------------|--|
| 02AQL367 | 2 m Power and Ethernet | 1 × Open wire end, 1 × RJ45 end |
| 02AQL368 | 5 m Power and Ethernet | 1 × Open wire end, 1 × RJ45 end |
| 02AQL369 | 10 m Power and Ethernet | 1 × Open wire end, 1 × RJ45 end |
| 02AQL370 | 15 m Power and Ethernet | 1 × Open wire end, 1 × RJ45 end |
| 02AQL371 | 20 m Power and Ethernet | 1 × Open wire end, 1 × RJ45 end |
| 02AQL372 | 25 m Power and Ethernet | 1 × Open wire end, 1 × RJ45 end |
| 02AQL385 | 2 m Power and Ethernet 90deg | 1 × Open wire end, 1 × RJ45 end, 90° connector |
| 02AQL386 | 5 m Power and Ethernet 90deg | 1 × Open wire end, 1 × RJ45 end, 90° connector |
| 02AQL387 | 10 m Power and Ethernet 90deg | 1 × Open wire end, 1 × RJ45 end, 90° connector |
| 02AQL388 | 15 m Power and Ethernet 90deg | 1 × Open wire end, 1 × RJ45 end, 90° connector |
| 02AQL389 | 20 m Power and Ethernet 90deg | 1 × Open wire end, 1 × RJ45 end, 90° connector |
| 02AQL390 | 25 m Power and Ethernet 90deg | 1 × Open wire end, 1 × RJ45 end, 90° connector |

I/O cable

Cable to connect the external I/O device to the sensor



| | | |
|----------------|---|--|
| Specifications | Sensor side | M16 connector (Straight or 90° upward-pointing can be selected) |
| | I/O device side | Flying lead |
| Communication | Encoder input (2-phase square-wave signals Phase A, Phase B, Phase Z), Trigger input, Digital output, RS-485 output | |

| Code No. | Product Name | Remarks |
|----------|----------------|------------------------------|
| 02AQL361 | 2 m I/O | Open wire end |
| 02AQL362 | 5 m I/O | Open wire end |
| 02AQL363 | 10 m I/O | Open wire end |
| 02AQL364 | 15 m I/O | Open wire end |
| 02AQL365 | 20 m I/O | Open wire end |
| 02AQL366 | 25 m I/O | Open wire end |
| 02AQL379 | 2 m I/O 90deg | Open wire end, 90° connector |
| 02AQL380 | 5 m I/O 90deg | Open wire end, 90° connector |
| 02AQL381 | 10 m I/O 90deg | Open wire end, 90° connector |
| 02AQL382 | 15 m I/O 90deg | Open wire end, 90° connector |
| 02AQL383 | 20 m I/O 90deg | Open wire end, 90° connector |
| 02AQL384 | 25 m I/O 90deg | Open wire end, 90° connector |

Note: Sensors cannot be synchronized by the signals input to and output from each sensor through this cable.



**Whatever your challenges are,
Mitutoyo supports you from start to finish.**

Mitutoyo is not only a manufacturer of top quality measuring products but one that also offers qualified support for the lifetime of the equipment, backed up by comprehensive services that ensure your staff can make the very best use of the investment.

Apart from the basics of calibration and repair, Mitutoyo offers product and metrology training, as well as IT support for the sophisticated software used in modern measuring technology. We can also design, build, test and deliver bespoke measuring solutions and even, if deemed cost-effective, take your critical measurement challenges in-house on a sub-contract basis.



**Find additional product literature
and our product catalogue**

<https://www.mitutoyo.co.jp/global.html>

Our products are classified as regulated items under Japanese Foreign Exchange and Foreign Trade Law. Please consult us in advance if you wish to export our products to any other country. If the purchased product is exported, even though it is not a regulated item (Catch-All controls item), the customer service available for that product may be affected. If you have any questions, please consult your local Mitutoyo sales office.

Note: Product illustrations are without obligation. Product descriptions, in particular any and all technical specifications, are only binding when explicitly agreed upon.
MITUTOYO and MICAT are either registered trademarks or trademarks of Mitutoyo Corp. in Japan and/or other countries/regions. Other product, company and brand names mentioned herein are for identification purposes only and may be the trademarks of their respective holders.
All information contained in this brochure is current as of June 2023.

Mitutoyo

Mitutoyo Corporation

20-1, Sakado 1-Chome,
Takatsu-ku, Kawasaki-shi,
Kanagawa 213-8533, Japan
T +81 (0) 44 813-8230
F +81 (0) 44 813-8231
<https://www.mitutoyo.co.jp>